

DEAD ENDS STRAPPING TOOL



FLE-UR-010-US

Note: Illustrative images

\GENERAL

\DESCRIPTION

AERIALGRIP® tools are manufactured by professionals and with optimum materials, guaranteeing durability and precision.

AERIALGRIP ® strapping tool is easy to handle due to its built-in cutter and screw rod system which provides better displacement allowing for faster application of bands, buckles, strapping and clamps. Aids in applications that require extra strength and added torque.

\ FEATURES

- Spin tension handle
- Heat treatment
- Tensions capability of over 2400 lb
- Blue epoxy powder coated corrosion resistance finish
- Spring loaded gripper lever



SPECIFICATIONS	
Compatible strap widths	1/4 in, 3/8 in, 1/2 in, 5/8 in, 3/4 in
Compatible thickness	0.0157, 0.0197, 0.023, 0.03, 0.0315, 0.039 in (0.4, 0.5, 0.6, 0.76, 0.8, 1.0 mm)
Max. Tension	2,400 lbs
Coating	Corrosion resistant blue epoxy powder
Handle	Spring loaded metallic gripper
Built-in cutter	Cuts off excess strap making the use of other tools safer and easier

\ APPLICATION

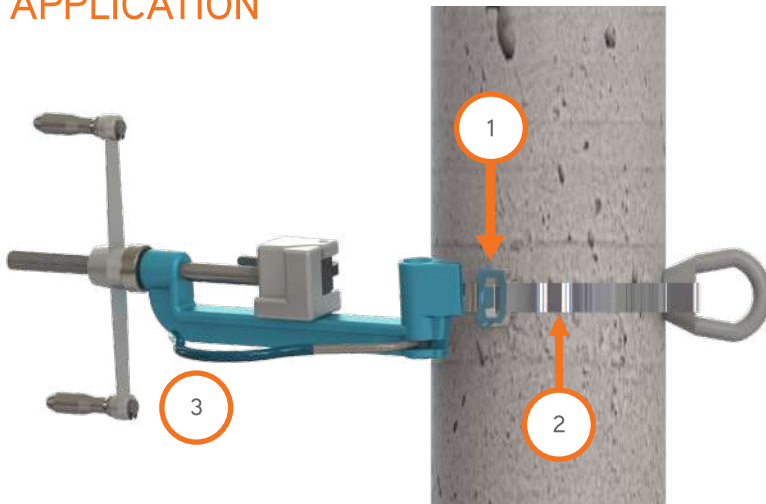

	CODE	DESCRIPTION
1)	HB-X/X-X-100	BUCKLE
2)	HF-X/X-30-PB II HF-XX-30	STRAP
3)	FLE-UR-010	STRAPPING TOOL

\ DIMENSIONS

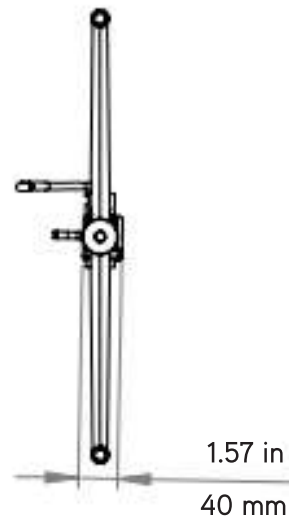
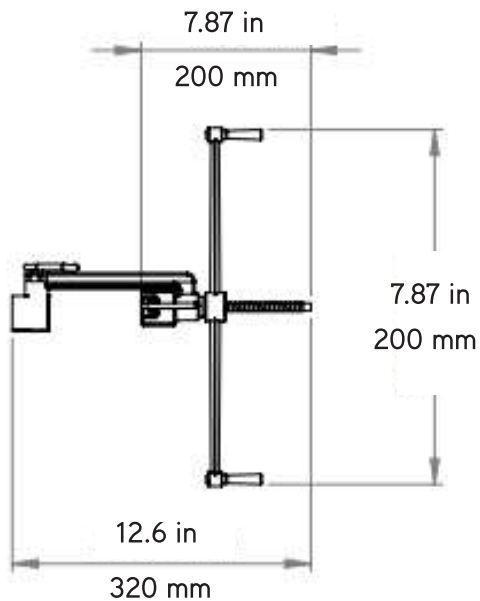

\ PACKAGING

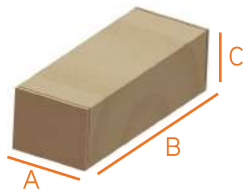

Fig. 3 Individual Packaging (1 pc)

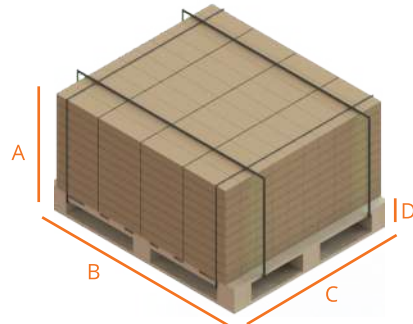

Fig. 4 Full pallet (500 pcs)

Box	A (in/mm)	B (in/mm)	C (in/mm)	Weight (lb/kg)
FLE-UR-010	3.9/100	10.6/270	3.15/80	15.8 / 1.95

Note:

Pallet	A (in/mm)	B (in/mm)	C (in/mm)	D (in/mm)	Weight (lb/kg)*
FLE-UR-010	37.4/950	48/1219.2	40/1016	5.5/140	2193.6/995

Note: *pallet weight (44.1 lb / 20 kg) included

\ LABELING SPECIFICATIONS



\ ORDERING MATRIX

\ STRAPPING TOOL

FLE-UR-010-US