

# WIRE CLAMPS

## WIRE CLAMP



HGZ-AG-US



HGJ-050-US

Note: Illustrative images

## \ GENERAL

### \ DESCRIPTION

The AERIALGRIP® Wire Clamps are ideal for telco and CATV aerial plant installations, to terminate and hold lashing wire or self supported cable to a messenger wire. They can also be used to hang splice cases and terminals from the messenger strand.

### \ FEATURES

AERIALGRIP HGJ-050 wire clamp:

- Manufactured with 12 gauge carbon steel sheet.
- Steel body and J hook.
- Highly useful in distribution networks and drop cable installations
- Electro galvanized to meet ASTM A-879

AERIALGRIP HGZ-AG wire clamp:

- Manufactured with hot-dip galvanized steel.
- High resistance under extreme weather conditions.
- Designed to firmly hold lashing cable terminations or interruptions in continuity.
- Compliant with ASTM A-153



\ APPLICATION

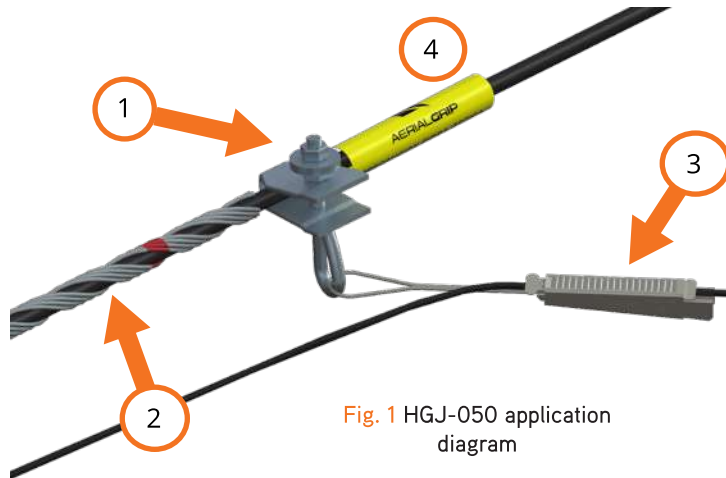
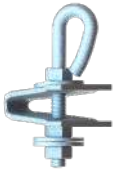
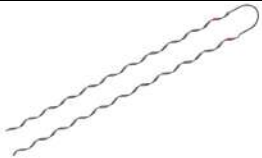



Fig. 1 HGJ-050 application diagram

Note: Illustrative images

\ RELATED HARDWARE

	CODE	DESCRIPTION	IMAGES
1	HGJ-050	TYPE J WIRE CLAMP	
2	HPXXXX-XX.X-XX.X	DEAD END FOR ADSS CABLE	
3	HG-AI-250	FIBER DROP CLAMP	
4	DN-XX-XX	FLAG MARKERS	

**\ DIMENSIONS**

**\ HGJ-050 wire clamp**

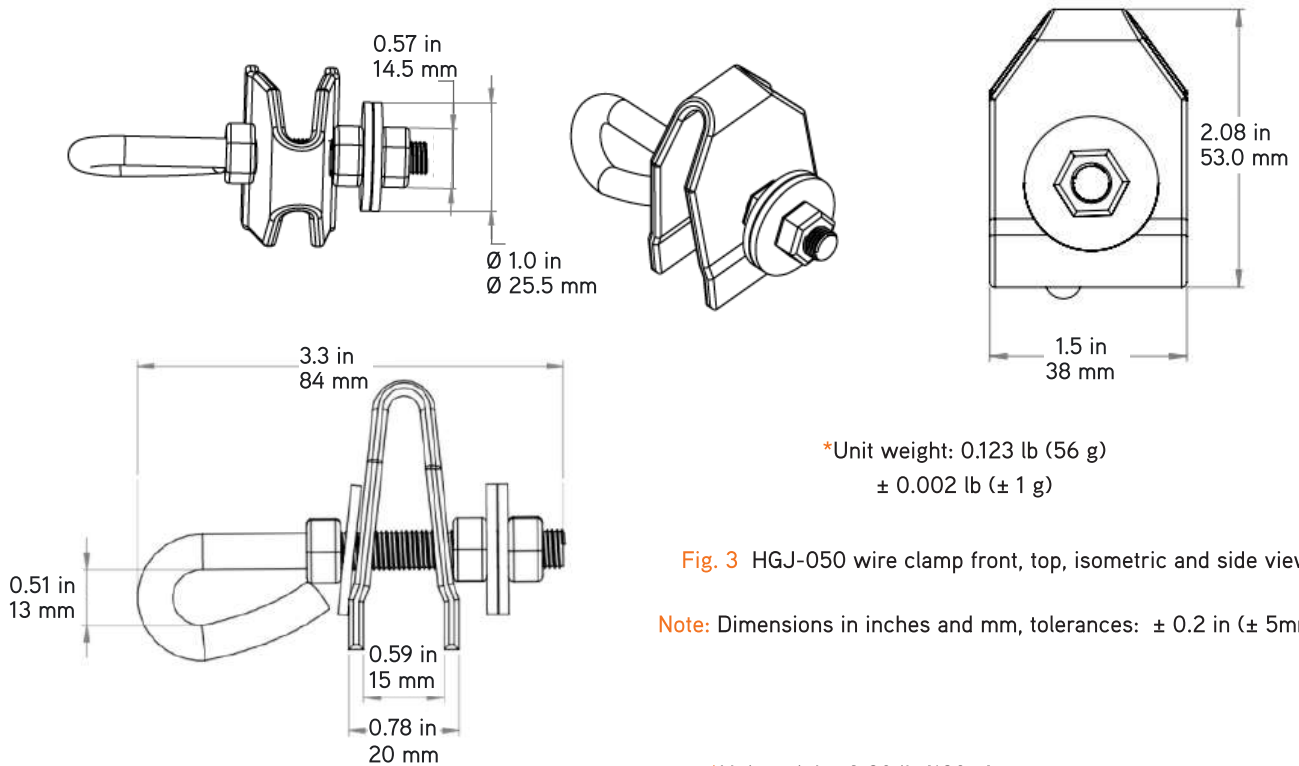

\*Unit weight: 0.123 lb (56 g)  
 $\pm 0.002$  lb ( $\pm 1$  g)

**Fig. 3** HGJ-050 wire clamp front, top, isometric and side views

**Note:** Dimensions in inches and mm, tolerances:  $\pm 0.2$  in ( $\pm 5$ mm)

\*Unit weight: 0.28 lb (128 g)  
 $\pm 0.002$  lb ( $\pm 1$  g)

**\ HGZ-AG wire clamp**

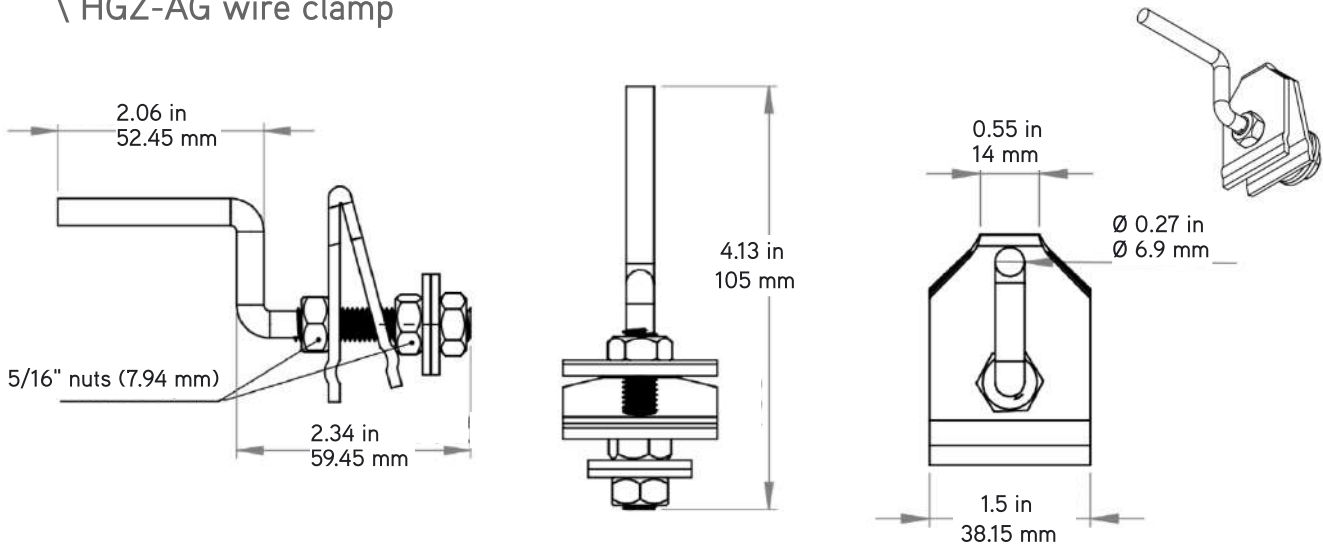

**Fig. 4** HGZ-AG wire clamp side, front, top and isometric views

**Note:** Dimensions in inches and mm, tolerances:  $\pm 0.2$  in ( $\pm 5$  mm)

\ PACKAGING

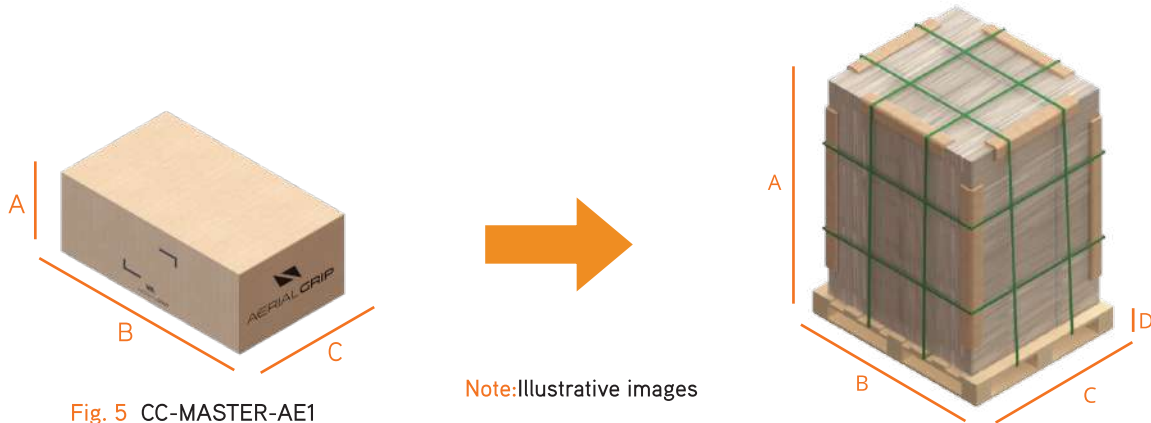

Fig. 5 CC-MASTER-AE1

Note: Illustrative images

Box	A (in/mm)	B (in/mm)	C (in/mm)	Weight (lb/kg)
1	7.75/197	19.9/505	11.65/296	12.34/5.6
2	7.75/197	19.9/505	11.65/296	28.22/12.8

Notes:  
 Box 1 - 100 pieces (HGJ-050)  
 Box 2 - 100 pieces (HGZ-AG)

Pallet	A (in/mm)	B (in/mm)	C (in/mm)	D (in/mm)	Weight (lb/kg)
1	45/1145	48/1219.2	40/1016	5.37/136.56	414.5/188*
2	45/1145	48/1219.2	40/1016	5.37/136.56	890.67/404*

Notes:  
 Pallet 1 - 3000 pieces total (HGJ-050)  
 Pallet 2 - 3000 pieces total (HGZ-AG)  
 \*Pallet weight included. (44 lb / 20 kg)

30 BOX PALLET: 3X2X5 ARRANGEMENT.

\ LABELING SPECIFICATIONS

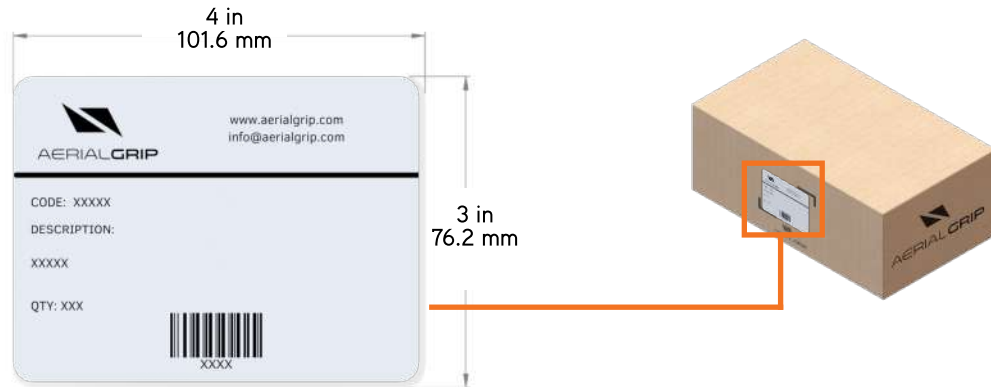

\ ORDERING MATRIX

\ HGJ-050 TYPE J WIRE CLAMP

**HGJ-050-US**

\ HGZ-AG TYPE Z WIRE CLAMP

**HGZ-AG-US**