

CABLE STORAGE SYSTEM

DOWNLEAD CLAMPS



HGFADSS-XX.X-XX.X-US

Note: Illustrative Images

\ GENERAL

\ DESCRIPTION

AERIALGRIP® Downlead clamps are used to guide ADSS cable from the top of the structure to the splice box while minimizing compression forces without damaging the plastic jacket.

Hot dipped galvanized parts with neoprene clamp splice that protects the ADSS cable, allowing an easy slide while under tension, preventing fiber optic cable fatigue. Different configurations available to match ADSS cable diameters. Steel strap included in all configurations.

\ FEATURES

- Firmly fixes ADSS cable to the post without damaging it
- Available for multiple ADSS cable diameters
- Light weight. (1.41 lb (640 g) approximately)
- Easy installation
- Hot dipped galvanized parts with neoprene clamp
- Contains two grooves
- No drilling holes



\ APPLICATION



Fig. 1 Download clamp application on wooden pole

	CODE	DESCRIPTION	IMAGE
1	HGFADSS-XX.X-XX.X	DOWNLEAD CLAMP WITH METAL STRAP FOR ADSS	
2	FOSPC-XXX-X -SSXXXXXXXX -XXXXX - XX	ADSS CABLE	

Note: Illustrative Images

\ DIMENSIONS

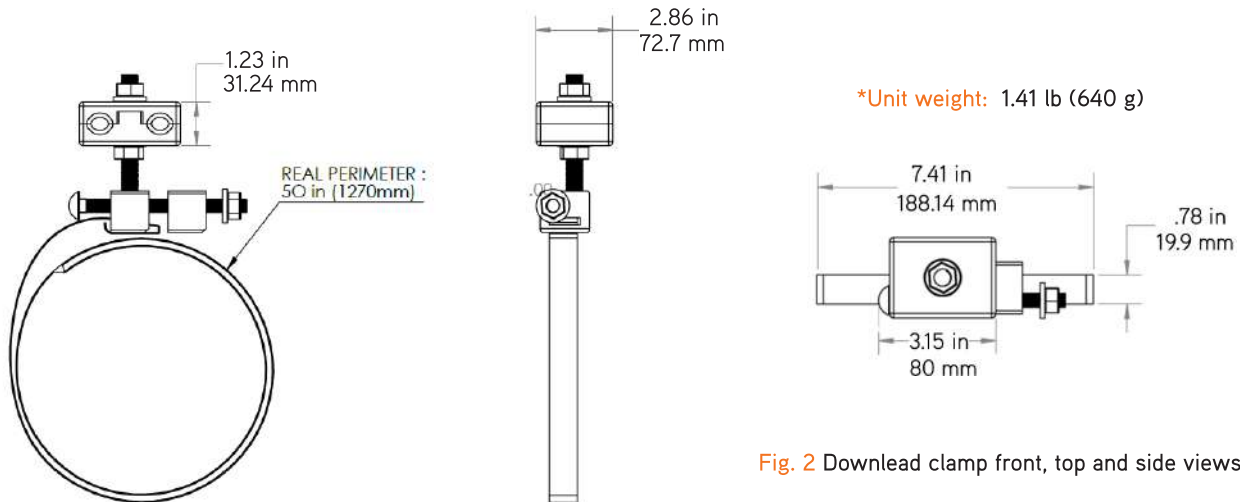
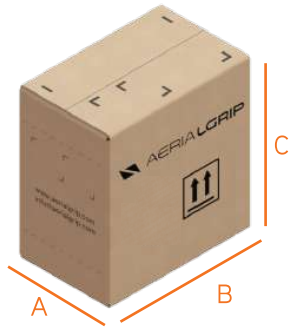

Fig. 2 Download clamp front, top and side views

\ LABELING SPECIFICATIONS



\ PACKAGING



B) CC-HERR6: 10 piece packaging

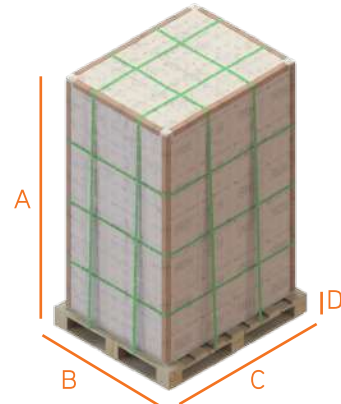

C) 120 box pallet

Box	A (in/mm)	B (in/mm)	C (in/mm)	Weight (lb/kg)
10 pcs.	6.89/175	11/280	11.42/290	14.1 lb /6.4 kg

Pallet	A (in/mm)	B (in/mm)	C (in/mm)	D (in/mm)	Weight (lb/kg)*
1200 pcs.	74.2/1885	40/1016	48/1219.2	5.37/136.56	1737 lb / 788 kg

Notes: 5X4X6 box arrangement.
*Pallet weight (44.1 lb/ 20 kg) included.

\ ORDERING MATRIX

HGFADSS-XX.X-XX.X-US

XX.X-XX.X - ADSS cable diameter

09.0-11.1 - 9.0 - 11.1 mm (0.354 - 0.430 in)

11.2-13.3 - 11.2.0 - 13.3 mm (0.440 - 0.520 in)

13.4-15.5 - 13.4 - 15.5 mm (0.521 - 0.610 in)

15.6-18.0 - 15.6 - 18.0 mm (0.614 - 0.700 in)