



FONCS

Fiber Optic Network Cable Solutions

Your network, our goal



Our Brands





Fiber Optic Network Cable Solutions

Your network, our goal

FONCS designs, manufactures, and distributes fiber optic solutions for telecommunications companies in North America.

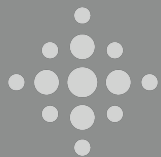

HISTORY

The **WAVEOPTICS®** brand was born with 1 Extrusion Line to manufacture Fiber Optic Cables, becoming one of the top **10 fiber optic cable manufacturers in North America** since then.

The **MEXFOSERV®** Cable Assembly Plant increased its production capacity, building a second Cleanroom to produce **large Trunk Cables for 5G applications**.

The **MEXFOSERV®** brand was born, providing high-quality Fiber Optic Cable **Assemblies, Passive Optical Components, and Demarcation Boxes** for indoor and outdoor fiber networks.

The **FUSIONGUARD®** brand was born, along with our new plastic injection molding plant to supply **Splice Closures and Multiport Service Terminals**.

FONCS® established a new warehouse in Laredo, TX. Improving our offering of **vertically integrated fiber optic solutions** to all of our customers in the US, Canada, and the Caribbean.

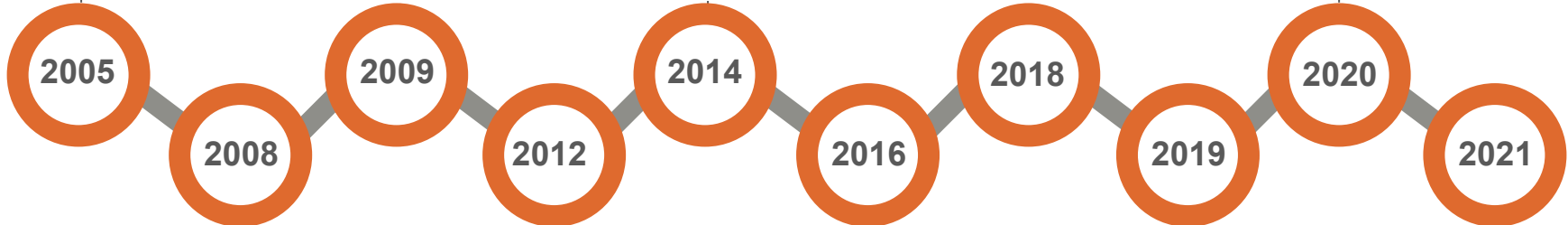

We moved our **Cable Termination Factory** and built a state-of-the-art Cleanroom, increasing our production capacity with **4 new automated production lines**.

The **AERIALGRIP®** brand was created, providing high-quality **Pole Hardware for FTTX installations**, fully matching our Fiber Optic Cable portfolio.

WAVEOPTICS® moved its operations to a new **75,000 square feet, ISO-9001 facility** to increase its total production capabilities to **2.4 million fiber kilometers per year**.

NEBKA LAB® was born, a complete Test Lab to perform **Mechanical and Optical Tests** on all our materials and fiber optic products according to all US and International Standards.

WAVEOPTICS® acquired **2 new lines** for the manufacturing of flat drop fiber optic cables, increasing the total production capabilities of its manufacturing plant.



WAVEOPTICS

Waveoptics® designs and manufactures **Fiber Optic Cables**
that exceed all of the U.S. and international requirements.

WAVEOPTICS® is one of the top 10 fiber optic cable manufacturers in North America.



Indoor-Outdoor Fiber Optic Cables

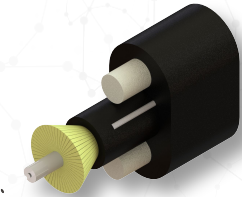

Flat Drop Indoor/Outdoor
Simplex Cables

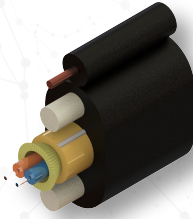

Flat Drop Indoor/Outdoor
Dual Cables

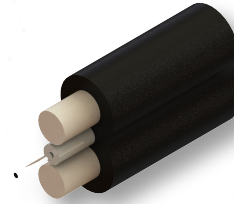

Micro Flat Drop
Cables

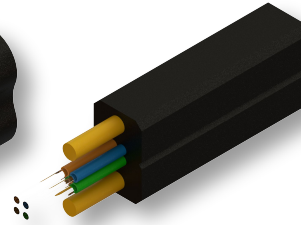

FTTH Drop
Cables

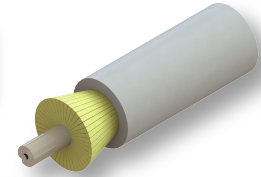

MDU Drop
Cables

Outdoor Fiber Optic Cables

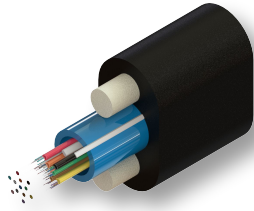

Flat Drop
Cables

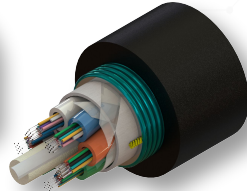

Loose Tube
Armored Cables

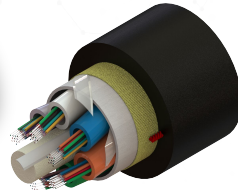

ADSS Cables

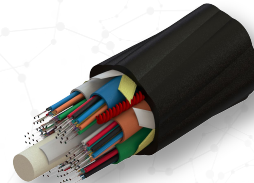

Air-Blown Micro Cables

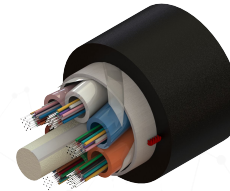

Loose Tube
All-Dielectric Cables

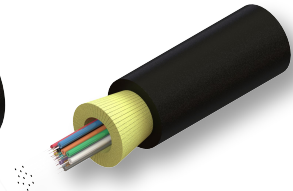

Pushable Cables

We **vertically integrate** our complete portfolio of Fiber Optic Cables with the rest of our manufacturing plants, meeting **specific customer requirements**.





Our **Fiber Optic Cable Manufacturing Plant** can produce most **Outdoor Plant Cables** as well as a large selection of **Indoor-Outdoor Cables** in their **different configurations**.

20 production lines for cable manufacturing ●

75,000 square feet of total production area ●

Installed capacity of over **2.4 million kilometers** of fiber per year ●



Check our **Manufacturing Plant Video Here**





AERIALGRIP

AERIAL GRIP® offers a **complete solution** for **Pole Cable Hardware** in FTTX and Outside Plant applications, ensuring an **effortless installation and identification, saving time and money.**

Our Products

Fiber Optic Hardware

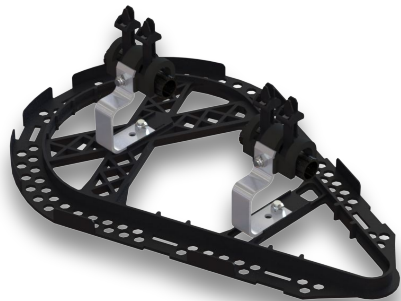

**Cable Storage
Systems**



**Tension
Hardware**

Manufacturing Plants

Our **Metal Stamping Plant** manufactures different **machined & metal stamped components**, complementing our product offering among our different brands.

Here we produce most of our **Metal Pole Hardware, Plastic Injection Molds, Tooling** required for our **cable factory, Metal Cabinets, Distributors, Cassettes, and LGX Faceplates**, providing an **economical and quick turnaround** to our customers.



AERIALGRIP

WWW.FONCS.COM

888 227 1072



Mexfoserv® offers a complete line of **connectivity-related products**. We offer **top quality & great lead times** that help our customers meet their fiber deployment targets enabling them the **lowest total cost of ownership**.

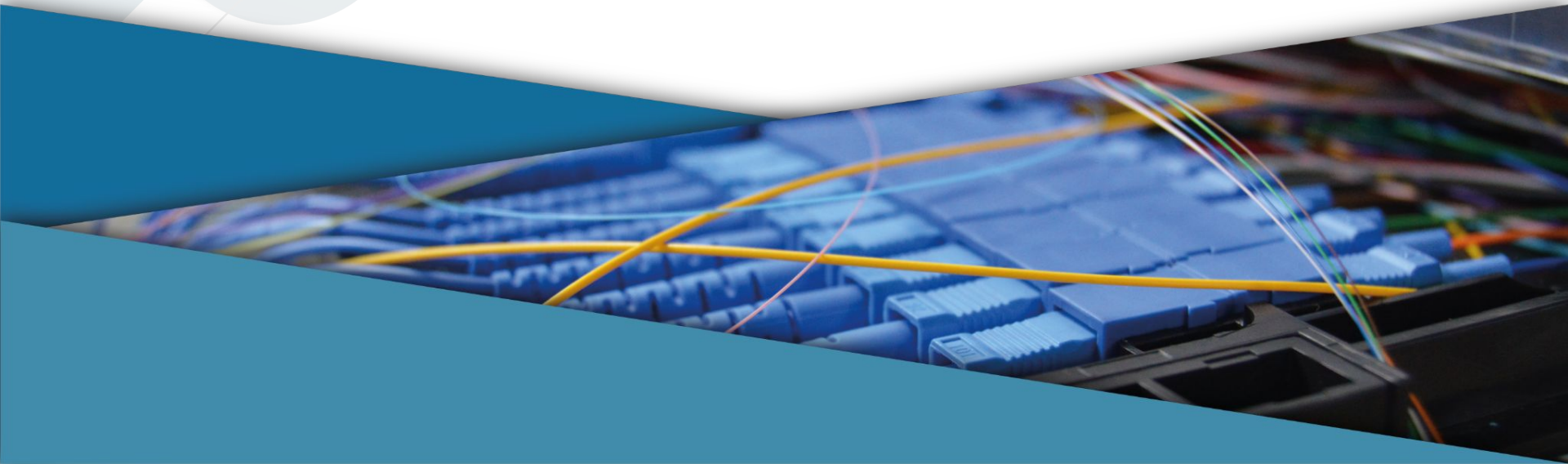

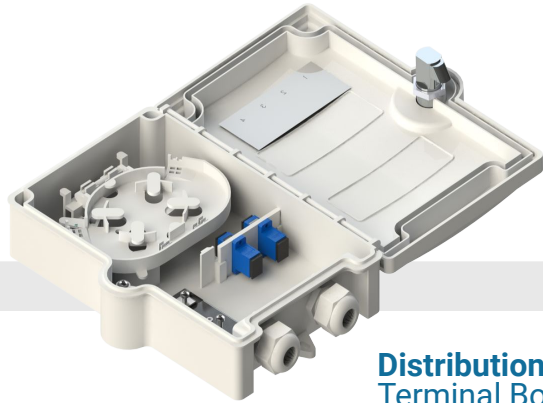

**Distribution
Terminal Boxes**

**Terminal
Boxes**

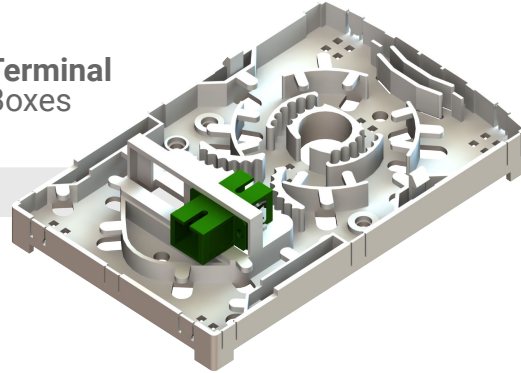

Our Fiber Optic Cable Assemblies, Passive Optical Components, and Demarcation Boxes are ideal for Broadband, CATV, Central Office/headend, data centers, and FTTH among other applications.



FIBER OPTIC ASSEMBLY PLANTS

With **3 state-of-the-art production facilities** and **Class 10000 ISO 7 Cleanrooms**, our Fiber Optic Assembly Plant manufactures its **high-performance products** in vertically integrated environments, ensuring their **reliability, and compatibility**.

Over **7000 square feet** of covering production areas ●

150,000 single-mode fiber ends and **5,000 MPO terminations** average output per month ●

Regulatory compliance with RoHS, ANSI/TIA, and Telcordia standards and requirements ●



Check our **Assembly Plant Video Here**



FUSIONGUARD

FUSIONGUARD® manufactures Splice Closures and Multiport Service Terminals, offering unique products for **Fiber Splicing, Repair, and Plug-and-play connections on the field.**

Our fiber optic closures are resistant to most outdoor conditions, with a variety of **IP-68 rated products**, this means, completely sealed against water and dust that have **great mechanical properties**, designed for **installations in manholes, handholes, and walls/poles.**

**Terminal Splice
Closures**



**Multiport Service
Terminals**





PLASTIC INJECTION PLANT

Our **Plastic Injection Molding plant** manufactures various products through our **4 injection molding machines** incorporated into our different brands: [splice closures](#), [splice trays](#), [fiber storage units](#), [terminal boxes](#), [plastic reels](#), as well as plastic accessories used in our [metal cabinets](#), [cable markers](#), and [pole hardware](#).





WHEN EXCELLENCE IS THE GOAL

Nebka Lab® is our **Quality Lab** to ensure the compliance of **Optical, Mechanical, and Environmental Tests** specified in our datasheets as well as to ensure the **compliance with US and International standards.**

We have the capability to test according to **Telcordia standards** (GR-20-CORE, GR-409-CORE, GR-326-CORE, GR-3120-CORE, GR-3173-CORE).

The optical, mechanical and environmental tests performed in **our laboratory** are:

Mechanical and Optical Performance Tests

- Torsion
- Polarization mode dispersion PMD
- Compression
- Impact
- Repeat Bending
- Outside Plant Tension
- Indoor Cable Tension
- Flexion
- Sheave test
- Kink

Environmental and Optical Performance Tests

- Simulation of Thermal and Humidity Cycles
- Water Penetration
- Bend to high and low temperatures
- Seepage of flooding or filling compound
- MID-SPAN
- Freezing
- Flammability
- Elongation
- Hydrolysis

Physical Performance Tests

- Abrasion
- Jacket Shrinkage
- Strippability
- Cable Compatibility and Aging
- Pull Tests
- Crack Resistance



WHEN EXCELLENCE IS THE GOAL

OUR LOCATION

Our **Warehouse located in Laredo, TX** serves as our main strategic location, allowing us to distribute our products quickly and efficiently, **reducing logistic costs.**



MEET OUR SALES TEAM



Miguel Green

Sales Manager

mgreen@foncs.com
EXT.110
956 962 2420



Diana Perez

Inside Sales Coordinator

dperez@foncs.com
EXT.101



Mariana Mares

Key Account
Executive

NC, SC, PA, VA, WV, MD
mmares@foncs.com
EXT. 106



Ricardo Romero

Key Account Executive
Master

PRIVATE LABELS & CONTRACT
MANUFACTURING
romero@foncs.com
EXT.103



Axel Rodriguez

Key Account Manager

arodriguezr@foncs.com
EXT. 108
956 401 0120



Oscar Berrueta

Key Account Executive

AR, MS & MO
oberrueta@foncs.com
EXT. 133
956 526 4025



Azul Sanchez

Inside Sales

AL, GA, TN & FL
asanchez@foncs.com
EXT.107



Fernanda Chavez

Inside Sales

DISTRIBUTORS
mchavez@foncs.com
EXT.103



Fernando Enriquez

Inside Sales

fenriquez@foncs.com
EXT. 111



Alan Camacho

Key Account Manager

acamacho@foncs.com
EXT. 102
312 576 7062



FONCS

Fiber Optic Network Cable Solutions

Your network, our goal

CONTACT



WWW.FONCS.COM



888 227 1072



sales@foncs.com

